

5/31/2024 6:19 PM
c:\users\yachmitta\building_drops_incl\building_drops_landing - common\projects\croft_llc\fbz-24-0404 - fbc submittal - 2023 fbc nami update\dwg\110853\crf026 2024-04-24.dwg

CROFT, LLC.

SERIES 4400/4440 SINGLE HUNG WINDOW (NON-HVHZ)(NON-IMPACT)



CROFT, LLC
1800 NORTH CLARK AVENUE
MAGNOLIA, MS 39652
PH: (800) 222-3195

GENERAL NOTES:

- THE PRODUCT SHOWN HEREIN IS DESIGNED AND MANUFACTURED TO COMPLY WITH THE CURRENT EDITION FLORIDA BUILDING CODE (FBC), EXCLUDING HVHZ AND HAS BEEN EVALUATED ACCORDING TO THE FOLLOWING:
 - AAMA/WDMA/CSA 101/I.S.2/A440-08/11
- ADEQUACY OF THE EXISTING STRUCTURAL CONCRETE/MASONRY, 2X FRAMING, AND METAL FRAMING AS A MAIN WIND FORCE RESISTING SYSTEM CAPABLE OF WITHSTANDING AND TRANSFERRING APPLIED PRODUCT LOADS TO THE FOUNDATION IS THE RESPONSIBILITY OF THE ENGINEER OR ARCHITECT OF RECORD FOR THE PROJECT OF INSTALLATION.
- 1X AND 2X BUCKS (WHEN USED) SHALL BE DESIGNED AND ANCHORED TO PROPERLY TRANSFER ALL LOADS TO THE STRUCTURE. BUCK DESIGN AND INSTALLATION IS THE RESPONSIBILITY OF THE ENGINEER OR ARCHITECT OF RECORD FOR THE PROJECT OF INSTALLATION.
- THE INSTALLATION DETAILS DESCRIBED HEREIN ARE GENERIC AND MAY NOT REFLECT ACTUAL CONDITIONS FOR A SPECIFIC SITE. IF SITE CONDITIONS CAUSE INSTALLATION TO DEVIATE FROM THE REQUIREMENTS DETAILED HEREIN, A LICENSED ENGINEER OR ARCHITECT SHALL PREPARE SITE SPECIFIC DOCUMENTS FOR USE WITH THIS DOCUMENT IN NON-HVHZ AREAS.
- APPROVED IMPACT PROTECTIVE SYSTEM **IS REQUIRED** ON THIS PRODUCT IN AREAS REQUIRING IMPACT RESISTANCE.
- WINDOW FRAME MATERIAL: ALUMINUM 6063-T5
- GLASS SHALL MEET THE REQUIREMENTS OF ASTM E 1300. SEE SHEET 1 FOR GLAZING DETAILS.

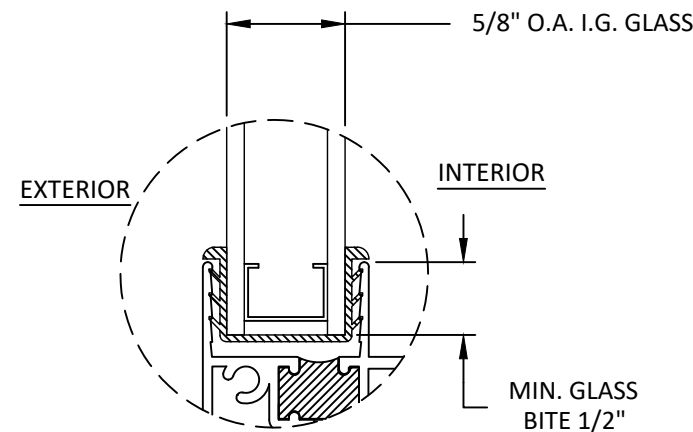

GLAZING DETAIL

GLAZING NOTES:

- GLASS TYPE SHALL COMPLY WITH ASTM E1300 REQUIREMENTS AS WELL AS APPLICABLE SAFETY GLAZING REQUIREMENTS PER THE FBC. TEMPER AND SAFETY GLAZING REQUIREMENTS SHALL BE REVIEWED ON A SITE SPECIFIC BASIS.
- SETTING BLOCK DUROMETER HARDNESS OF 70-90 (SHORE A) AS REFERENCED IN FBC CHAPTER 24.
- SETTING BLOCKS TO BE LOCATED AT 1/4 SPAN LENGTH FOR GLASS WIDER THAN 36" AS PER FBC CHAPTER 24.
- D.L.O. AND DESIGN PRESSURES MAY NOT EXCEED MAX VALUES IN DESIGN PRESSURE TABLE ON SHEET 1.

TABLE OF CONTENTS	
SHEET	SHEET DESCRIPTION
1	GENERAL NOTES & GLAZING DETAIL
2	ELEVATION & ANCHOR LAYOUTS
3	VERTICAL SECTION
4	HORIZONTAL SECTIONS
5	ANCHOR DETAILS & INSTALLATION NOTES

MAX OVERALL SIZE		MAX SASH SIZE		MAX D.L.O. SIZE		CONFIG.	DESIGN PRESSURE	MISSILE IMPACT RATING
WIDTH	HEIGHT	WIDTH	HEIGHT	WIDTH	HEIGHT			
35-3/8"	71-1/2"	33"	35-3/4"	30-7/8"	32-1/2"	O/X	+/- 50 PSF	NON-IMPACT
48"	72"	45-5/8"	29-3/4"	43-5/16"	38-3/4"			
70-3/4"	71-1/2"	33"	35-3/4"	30-7/8"	32-1/2"	O/XO/X		
72"	72"	33-1/2"	29-9/16"	31-3/8"	38-3/4"			

TITLE: **SERIES 4400/4440
SINGLE HUNG WINDOW
(NON-HVHZ) (NON-IMPACT)**
GENERAL NOTES & GLAZING DETAIL

PREPARED BY: **BUILDING DROPS, INC.**
1900 NE MIAMI CT. SUITE 2-15
MIAMI, FL 33132
PH: (954) 399-8478
FAX: (954) 744-4738
WEB: www.buildingdrops.com



REMARKS	BY	DATE
FBC NAMI UPDATE	RN	4/26/24

THE INSTALLATION DETAILS DESCRIBED HEREIN ARE GENERIC AND MAY NOT REFLECT ACTUAL CONDITIONS FOR A SPECIFIC SITE. IF SITE CONDITIONS CAUSE INSTALLATION TO DEVIATE FROM THE REQUIREMENTS DETAILED HEREIN, A LICENSED ENGINEER OR ARCHITECT SHALL PREPARE SITE SPECIFIC DOCUMENTS FOR USE WITH THIS DOCUMENT.

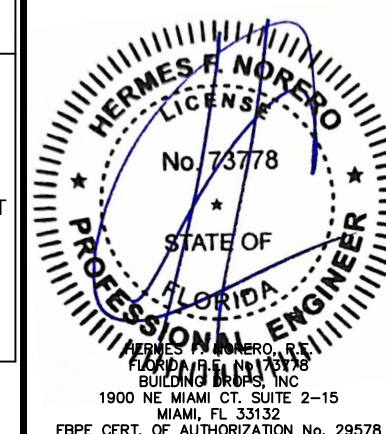

FL #: **FL10853**

DATE: **08.08.21**

DWG. BY: **AC** CHK. BY: **HFN**

SCALE: **NTS**

DWG. #: **CRF026**

SHEET

1

5/31/2024 6:19 PM
c:\users\yvuichitta\building_drops, inc\building_drops landing - common\projects\croft llc\fbcr-24-0404 - fbc submittal - 2023 fbc nami update\dwg\110853\crf026 2024-04-24.dwg



CROFT, LLC
1800 NORTH CLARK AVENUE
MAGNOLIA, MS 39652
PH: (800) 222-3195

TITLE: **SERIES 4400/4440
SINGLE HUNG WINDOW
(NON-HVHZ) (NON-IMPACT)**
ELEVATIONS AND ANCHOR LAYOUTS

PREPARED BY: **BUILDING DROPS, INC.**
1900 NE MIAMI CT, SUITE 2-15
MIAMI, FL 33132
PH: (954) 399-8478
FAX: (954) 744-4738
WEB: www.buildingdrops.com



REMARKS	BY	DATE
FBC NAMI UPDATE	RN	4/26/24

THE INSTALLATION DETAILS DESCRIBED HEREIN ARE GENERIC AND MAY NOT REFLECT ACTUAL CONDITIONS FOR A SPECIFIC SITE. IF SITE CONDITIONS CAUSE INSTALLATION TO DEVIATE FROM THE REQUIREMENTS DETAILED HEREIN, A LICENSED ENGINEER OR ARCHITECT SHALL PREPARE SITE SPECIFIC DOCUMENTS FOR USE WITH THIS DOCUMENT.

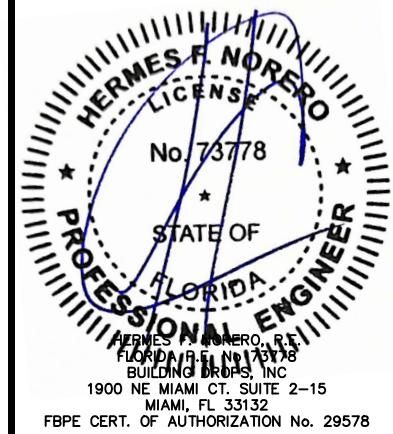

FL #:	FL10853
DATE:	08.08.21
DWG. BY:	AC
CHK. BY:	HFN
SCALE:	NTS
DWG. #:	CRF026

SHEET
2
OF 5

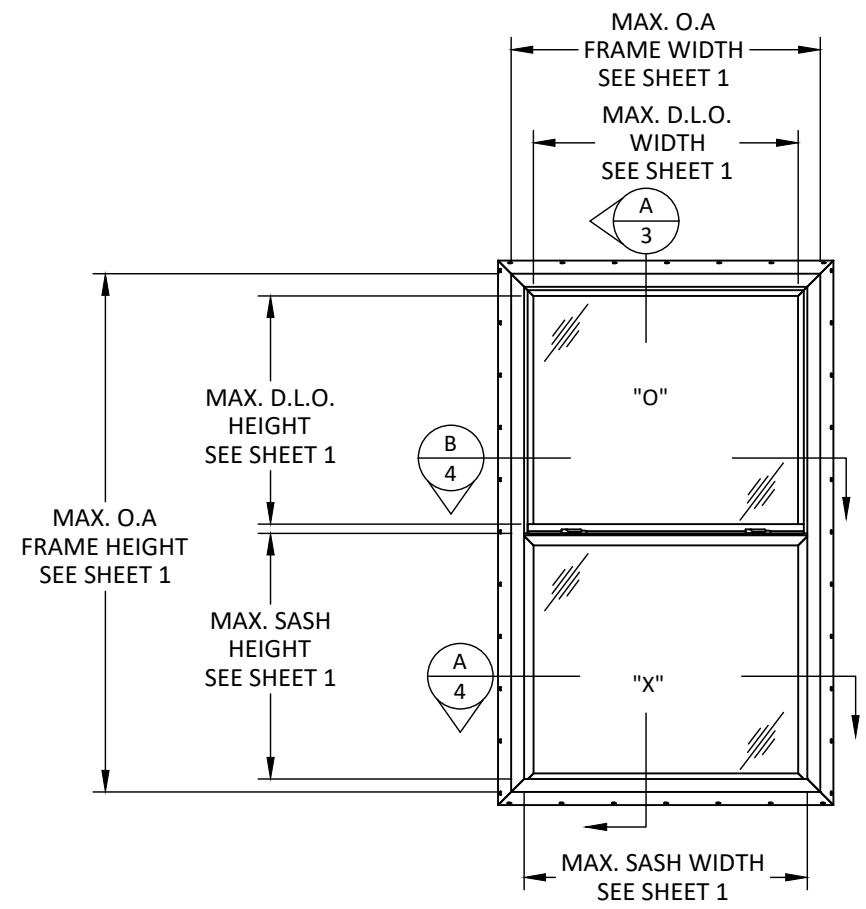

ELEVATION
SINGLE HUNG WINDOW

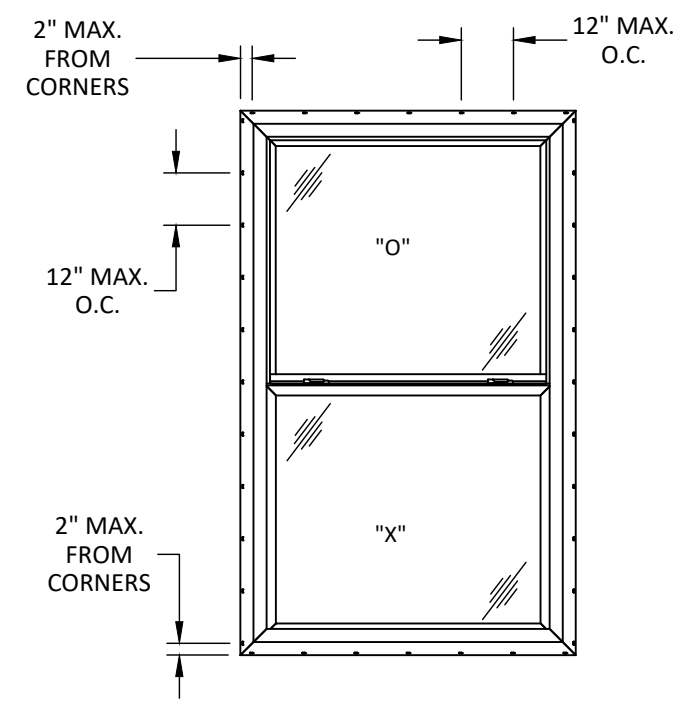

ANCHOR LAYOUT
NAIL FIN - SINGLE HUNG WINDOW

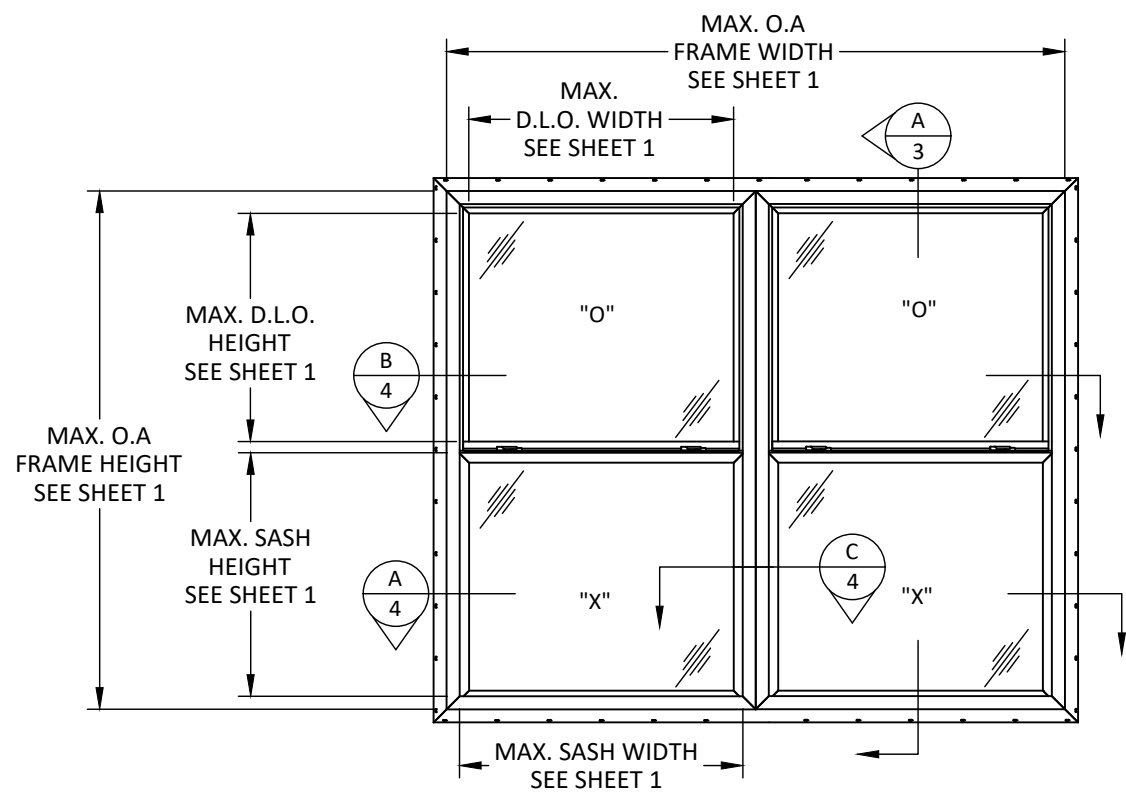

ELEVATION
TWIN SINGLE HUNG WINDOW

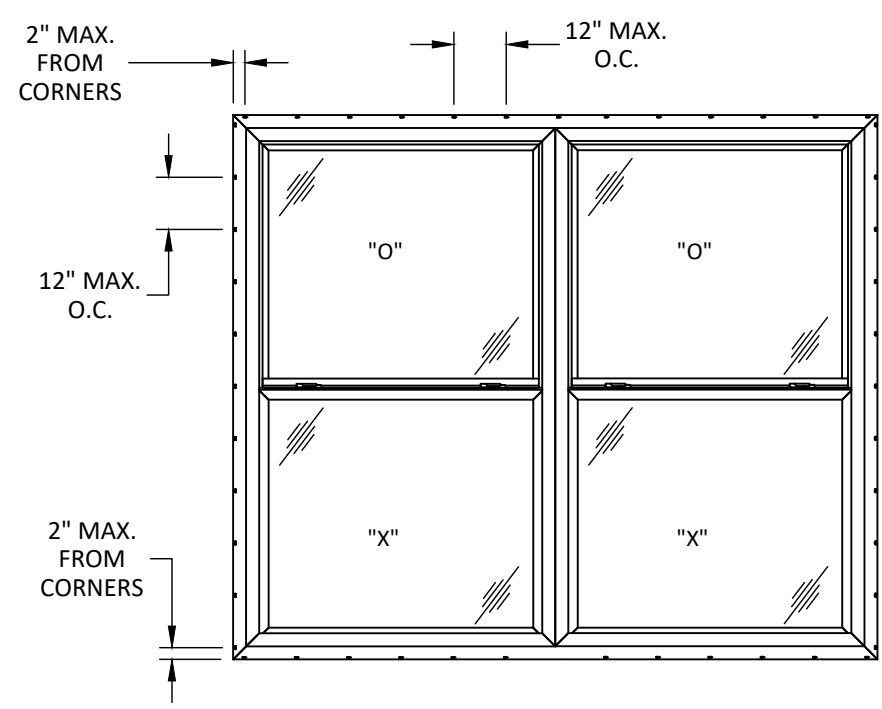

ANCHOR LAYOUT
NAIL FIN - TWIN SINGLE HUNG WINDOW

c:\users\y\chitt\building drops, inc\building drops landing - common\projects\croft, llc\fbcr-24-0404 - fbc submittal - 2023 fbc nami update\dwg\110853\crf026 2024-04-24.dwg 5/31/2024 6:19 PM

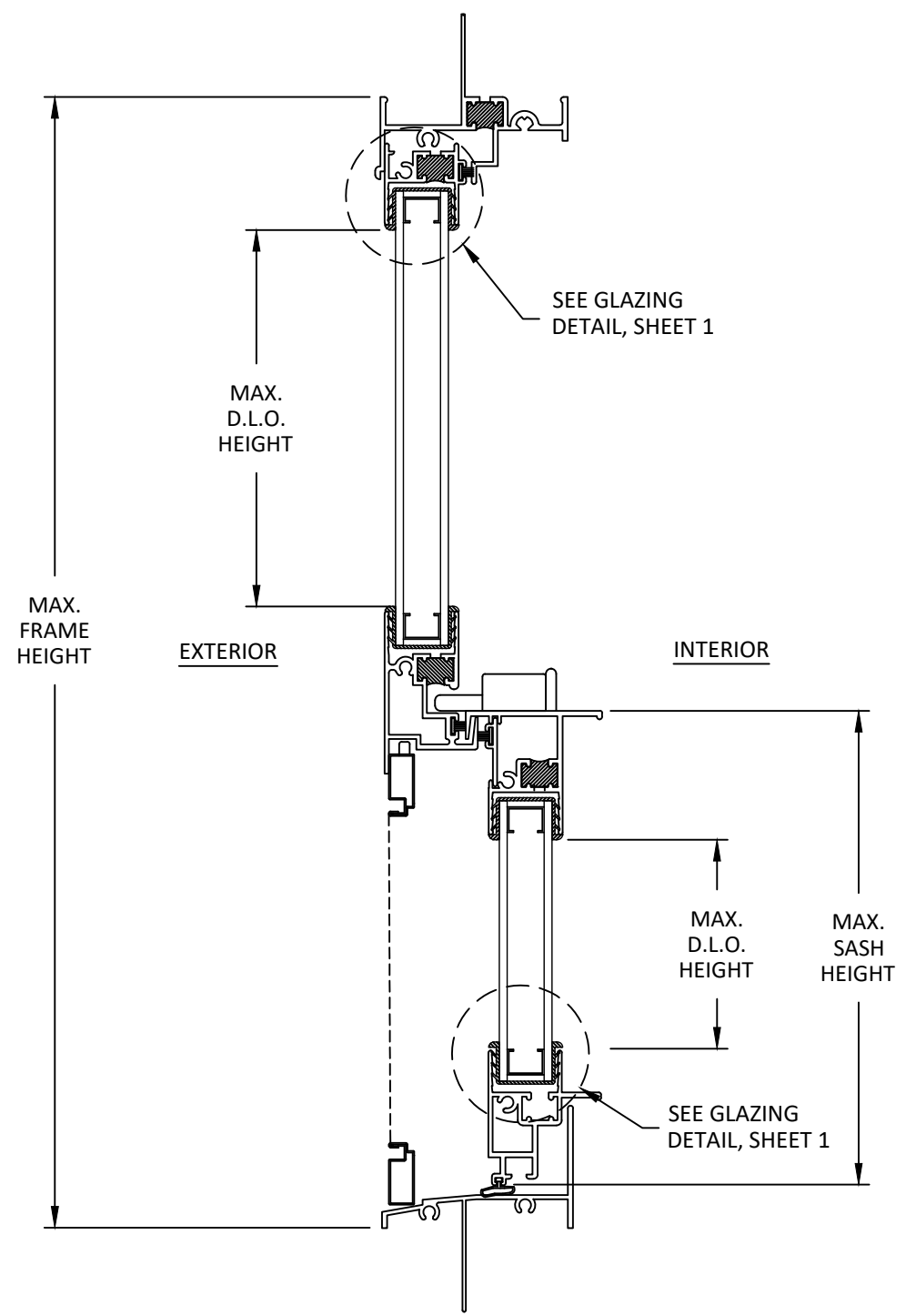

A
3 **VERTICAL SECTION**
NAIL FIN

NOTE:
COMPONENTS MAY BE USED IN
THERMALLY-BROKEN OR
UNTHERMALLY-BROKEN APPLICATIONS.



CROFT, LLC
1800 NORTH CLARK AVENUE
MAGNOLIA, MS 39652
PH: (800) 222-3195

TITLE:
SERIES 4400/4440
SINGLE HUNG WINDOW
(NON-HVHZ) (NON-IMPACT)
VERTICAL SECTION

PREPARED BY:
BUILDING DROPS, INC.
1900 NE MIAMI CT, SUITE 2-15
MIAMI, FL 33132
PH: (954)399-8478
FAX: (954)744-4738
WEB: www.buildingdrops.com



REMARKS	BY	DATE
FBC NAMI UPDATE	RN	4/26/24

THE INSTALLATION DETAILS DESCRIBED HEREIN ARE GENERIC AND MAY NOT REFLECT ACTUAL CONDITIONS FOR A SPECIFIC SITE. IF SITE CONDITIONS CAUSE INSTALLATION TO DEVIATE FROM THE REQUIREMENTS DETAILED HEREIN, A LICENSED ENGINEER OR ARCHITECT SHALL PREPARE SITE SPECIFIC DOCUMENTS FOR USE WITH THIS DOCUMENT.

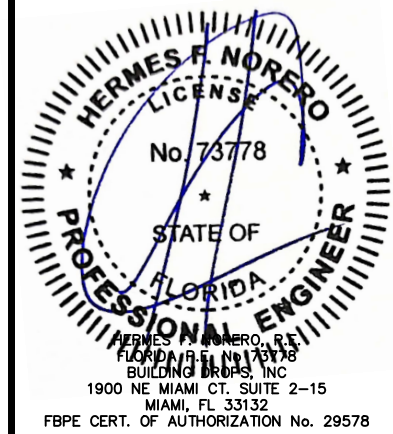

FL #:
FL10853

DATE: **08.08.21**

DWG. BY: **AC** CHK. BY: **HFN**

SCALE: **NTS**

DWG. #: **CRF026**

SHEET

3

OF 5

c:\users\yvuichintra\building_drops, inc\projects\croft, llc\fbcr-24-0404 - fbc submittal - 2023 fbc nami update\dwg\10853\crf026 2024-04-24.dwg



CROFT, LLC
1800 NORTH CLARK AVENUE
MAGNOLIA, MS 39652
PH: (800) 222-3195

TITLE: **SERIES 4400/4440
SINGLE HUNG WINDOW
(NON-HVHZ) (NON-IMPACT)
HORIZONTAL SECTIONS**

PREPARED BY: **BUILDING DROPS, INC.**
1900 NE MIAMI CT, SUITE 2-15
MIAMI, FL 33132
PH: (954) 399-8478
FAX: (954) 744-4738
WEB: www.buildingdrops.com

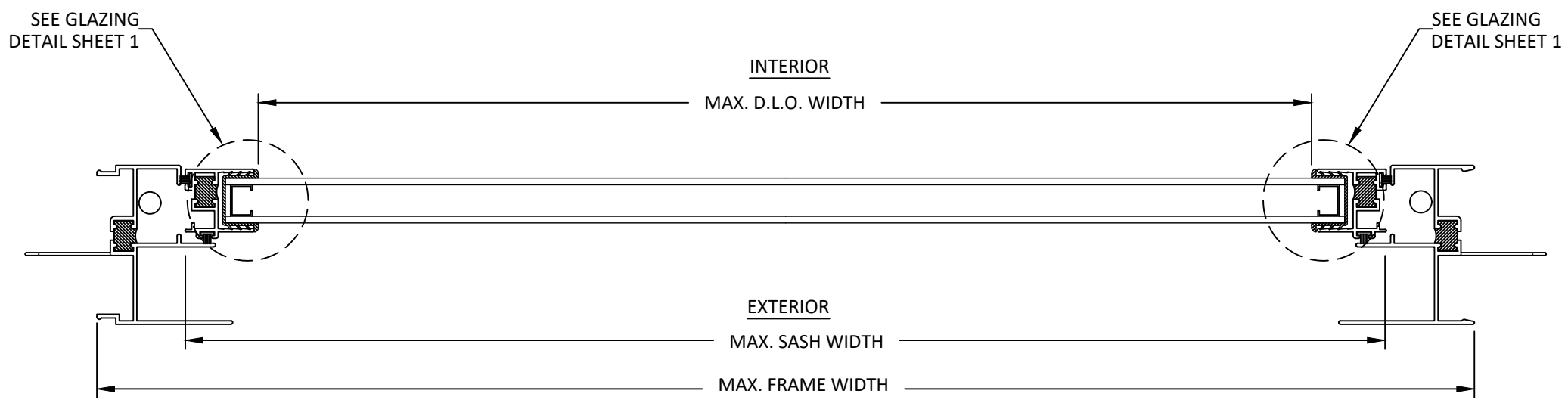

A
4 **HORIZONTAL SECTION**
LOWER SASH

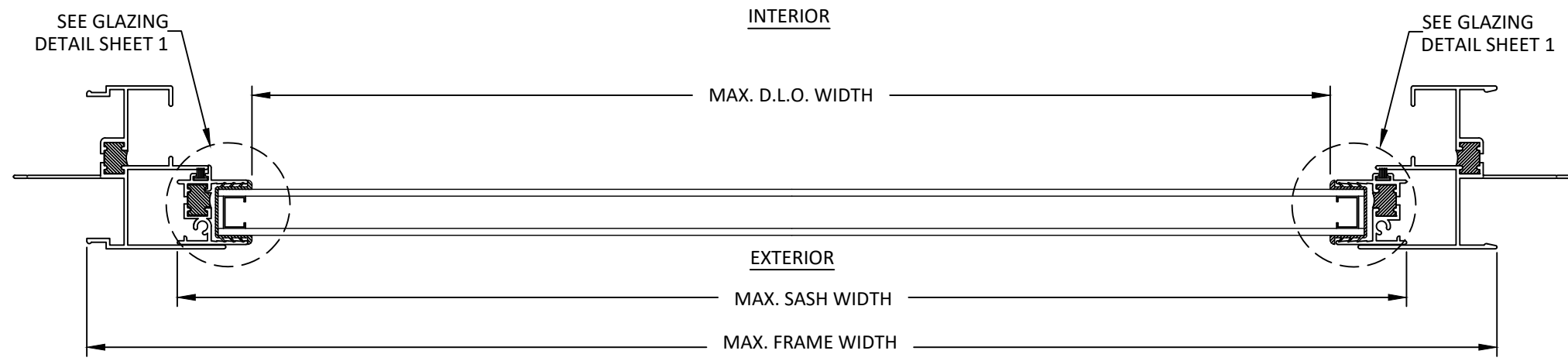

B
4 **HORIZONTAL SECTION**
UPPER FIXED LITE

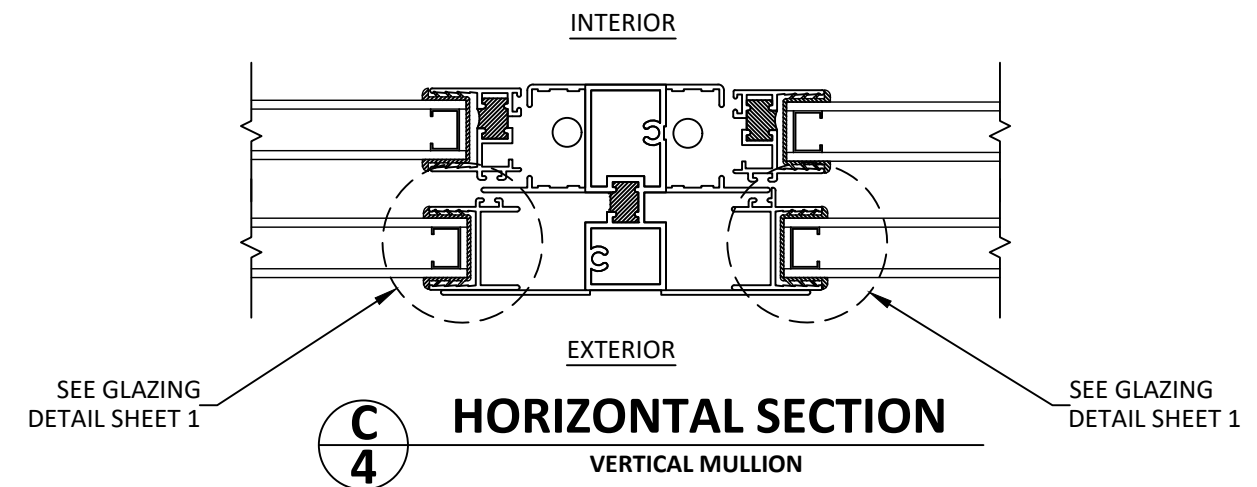

C
4 **HORIZONTAL SECTION**
VERTICAL MULLION

NOTE:
COMPONENTS MAY BE USED IN
THERMALLY-BROKEN OR
UNTHERMALLY-BROKEN APPLICATIONS.

REMARKS	BY	DATE
FBC NAMI UPDATE	RN	4/26/24

THE INSTALLATION DETAILS DESCRIBED HEREIN ARE GENERIC AND MAY NOT REFLECT ACTUAL CONDITIONS FOR A SPECIFIC SITE. IF SITE CONDITIONS CAUSE INSTALLATION TO DEVIATE FROM THE REQUIREMENTS DETAILED HEREIN, A LICENSED ENGINEER OR ARCHITECT SHALL PREPARE SITE SPECIFIC DOCUMENTS FOR USE WITH THIS DOCUMENT.

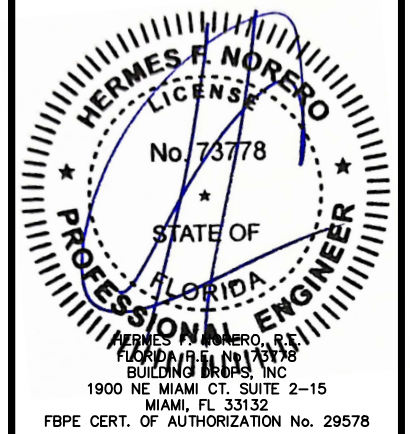

FL #:	FL10853
DATE:	08.08.21
DWG. BY:	AC
CHK. BY:	HFN
SCALE:	NTS
DWG. #:	CRF026

SHEET
4
OF 5

5/31/2024 6:19 PM
c:\users\yvuichitra\building_drops, inc\building_drops, inc\projects\croft, llc\fbcr-24-0404 - fbc submittal - 2023 fbc nami update\dwg\10853\crf026 2024-04-24.dwg

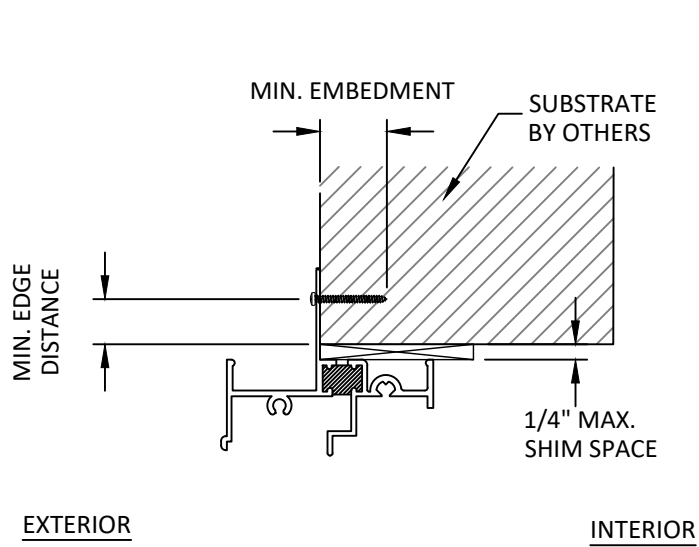

A
5 **HORIZONTAL SECTION**
NAIL FIN (HEAD)

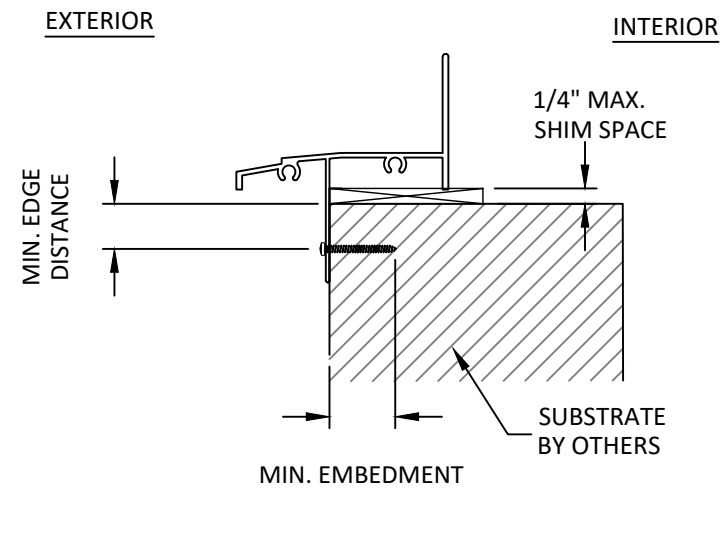

B
5 **HORIZONTAL SECTION**
NAIL FIN (SILL)

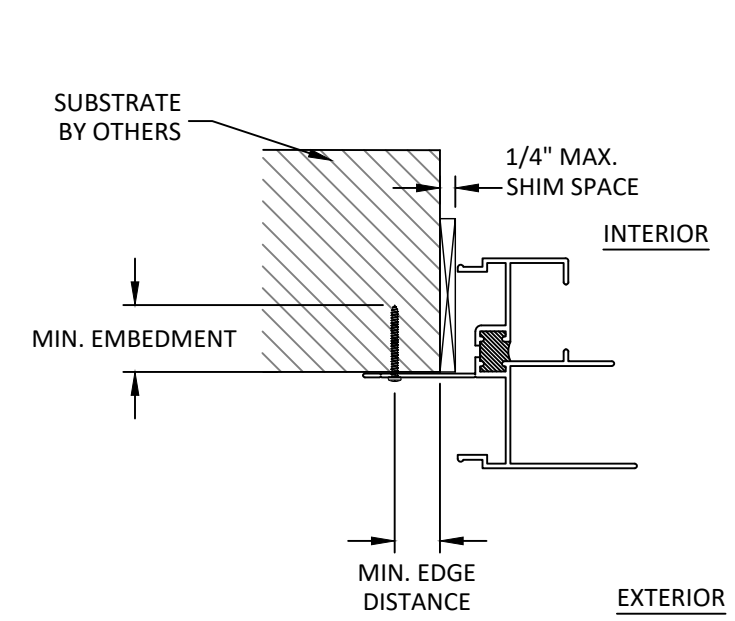

C
5 **HORIZONTAL SECTION**
NAIL FIN (JAMB)

INSTALLATION NOTES:

- ONE (1) INSTALLATION ANCHOR IS REQUIRED AT EACH ANCHOR LOCATION SHOWN.
- THE NUMBER OF INSTALLATION ANCHORS DEPICTED IS THE MINIMUM NUMBER OF ANCHORS TO BE USED FOR PRODUCT INSTALLATION OF THE MAXIMUM SIZE LISTED.
- INSTALL INDIVIDUAL INSTALLATION ANCHORS WITHIN A TOLERANCE OF ±1/2 INCH THE DEPICTED LOCATION & SPACING IN THE ANCHOR LAYOUT DETAILS (I.E., WITHOUT CONSIDERATION OF TOLERANCES). TOLERANCES ARE NOT CUMULATIVE FROM ONE INSTALLATION ANCHOR TO THE NEXT.
- SHIM AS REQUIRED WITH LOAD BEARING SHIM(S) TO ACHIEVE A SQUARE AND PLUMB INSTALLATION. MAXIMUM ALLOWABLE SHIM STACK TO BE 1/4 INCH. SHIM WHERE SPACE OF 1/16 INCH OR GREATER OCCURS. SHIM(S) SHALL BE CONSTRUCTED OF HIGH DENSITY PLASTIC OR BETTER.
- MINIMUM EMBEDMENT AND EDGE DISTANCE EXCLUDE WALL FINISHES, INCLUDING BUT NOT LIMITED TO STUCCO, FOAM, BRICK VENEER, AND SIDING.
- INSTALLATION ANCHORS AND ASSOCIATED HARDWARE MUST BE MADE OF CORROSION RESISTANT MATERIAL OR HAVE A CORROSION RESISTANT COATING.
- INSTALLATION ANCHORS SHALL BE INSTALLED IN ACCORDANCE WITH ANCHOR MANUFACTURER'S INSTALLATION INSTRUCTIONS, AND ANCHORS SHALL NOT BE USED IN SUBSTRATES WITH STRENGTHS LESS THAN THE MINIMUM STRENGTH SPECIFIED BY THE ANCHOR MANUFACTURER.

ANCHOR SCHEDULE				
METHOD	SUBSTRATE	ANCHOR TYPE	MIN EMBEDMENT	MIN. EDGE DISTANCE
NAILING FIN	WOOD: MIN. SG = 0.55	#8 WOOD SCREW PAN HEAD	1.5"	0.75"
	METAL: 18 GAUGE STEEL, MIN. Fy = 33KSI	#8 SMS OR SELF-DRILLING SCREWS	3 THREADS MIN PENETRATION BEYOND METAL	0.50"

 CROFT, LLC
 1800 NORTH CLARK AVENUE
 MAGNOLIA, MS 39652
 PH: (800) 222-3195

TITLE: **SERIES 4400/4440 SINGLE HUNG WINDOW (NON-HVHZ) (NON-IMPACT)**
 ANCHOR DETAILS & INSTALLATION NOTES
 PREPARED BY: **BUILDING DROPS, INC.**
 1900 NE MIAMI CT, SUITE 2-15
 MIAMI, FL 33132
 PH: (954) 399-8478
 FAX: (954) 744-4738
 WEB: www.buildingdrops.com

REMARKS	BY	DATE
FBC NAMI UPDATE	RN	4/26/24

THE INSTALLATION DETAILS DESCRIBED HEREIN ARE GENERIC AND MAY NOT REFLECT ACTUAL CONDITIONS FOR A SPECIFIC SITE. IF SITE CONDITIONS CAUSE INSTALLATION TO DEVIATE FROM THE REQUIREMENTS DETAILED HEREIN, A LICENSED ENGINEER OR ARCHITECT SHALL PREPARE SITE SPECIFIC DOCUMENTS FOR USE WITH THIS DOCUMENT.

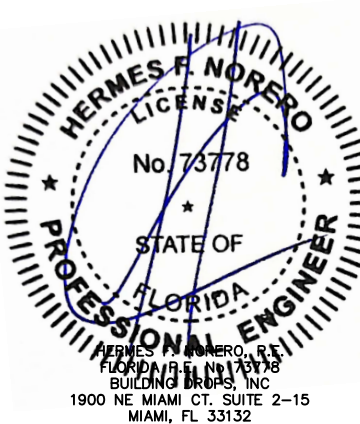
HERMES F. NORERO
 LICENSE
 No. 73778
 STATE OF
 FLORIDA
 PROFESSIONAL ENGINEER
 HERMES F. NORERO, P.E.
 FLORIDA LICENSE NO. 73778
 BUILDING DROPS, INC.
 1900 NE MIAMI CT, SUITE 2-15
 MIAMI, FL 33132
 FBPE CERT. OF AUTHORIZATION No. 29578

FL #: **FL10853**
 DATE: **08.08.21**
 DWG. BY: **AC** CHK. BY: **HFN**
 SCALE: **NTS**
 DWG. #: **CRF026**
 SHEET
5